



ENCARDIO RITE

CRACK & JOINT METERS

**MODELS EDJ-40C CRACK METER,
EDJ-41M CRACK/JOINT METER &
EDJ-40TJ TRIAXIAL JOINT METER**

INTRODUCTION

Encardio-rite crack & joint meters are ideally suited for measurement of movement. These measurements are important for monitoring the behaviour of civil structures and buildings.

The crack meter is used to measure change in width of a surface crack. It is used to monitor cracks in concrete structures, rock, bridges, pavement slabs, etc.. The joint meter is ideally suited for measurement of displacement/movement across joints such as joint opening between two concrete/masonry blocks in a dam.

MODEL EDJ -40C CRACK METER

The model EDJ-40C crack meter can measure the change in width of a surface crack with a resolution of 0.5 mm. It consists of a graduated scale with a resolution of 0.5 mm and a transparent acrylic plate with a hairline cursor mark. The graduated scale and the

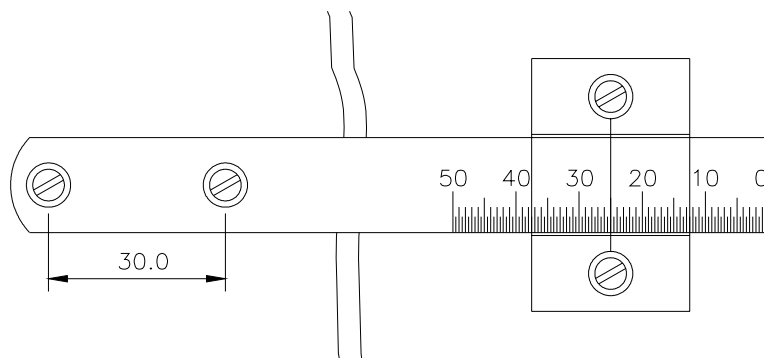

Model EDJ-40C crackmeter

transparent acrylic plate are assembled across the crack with expandable anchors in 5 mm diameter holes drilled to a depth of 30 mm as shown in the figure.

As the crack opens or closes, the graduated scale and the cursor

FEATURES

- ◆ Reliable & accurate.
- ◆ Simple to install.
- ◆ Simple to read.
- ◆ Rugged construction.
- ◆ Low cost.

APPLICATIONS

Crack meter: to monitor cracks in:

- ◆ Concrete and arch dams.
- ◆ Concrete structures.
- ◆ Rock, soil and masonry structures
- ◆ Buildings affected due to nearby construction or excavation activity.

Joint meter: to measure mass movement in:

- ◆ Construction and submerged joints in concrete dams.
- ◆ Bridges.
- ◆ Tunnels and shaft linings.
- ◆ Rock, soil and masonry structures.

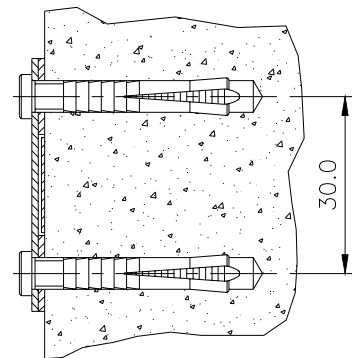

move relative to each other representing the amount of movement occurring. The reading of the marking is initially noted and is taken as a base.

MODEL EDJ-41M CRACK/JOINT METER

The model EDJ-41M is used for monitoring of cracks, joints and fissures.

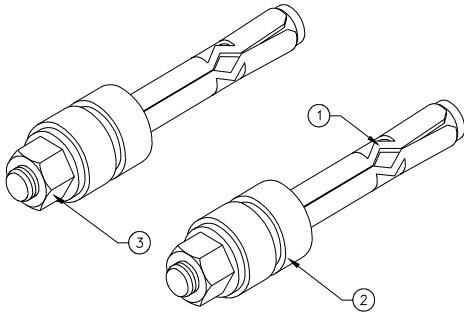

It consists of two stainless steel round datum blocks (2) that are installed on either side of the opening. Each datum block has a groove on the surface along the circumference to assist in taking readings. A through mounting hole helps mounting the datum block on concrete, masonry or rock surface using expandable anchors (1). M8 nuts (3) are provided to tighten the expandable anchor.

The distance between the grooves of the datum blocks is initially measured by a digital inside caliper with a resolution of 0.01 mm.

MODEL EDJ-40TJ TRIAXIAL JOINT METER

Encardio-rite model EDJ-TJ triaxial jointmeter is used for surface measurement. Surface joint measurements can be made either on the surface or at locations accessible from galleries.

The Encardio-rite model EDJ-40TJ triaxial jointmeter for surface measurement consists of two zinc plated



precision machined elements attached to reinforced bar anchor stems. The measurement is made by anchoring the two elements on either side of the joint and accurately measuring the distance between them over a period of time.

The range of model EDJ-40TJ jointmeter is ± 15 mm in XYZ direction. The measurement is made by anchoring the two elements on either side of the joint and accurately measuring the change in distance between them over a period of time. The displacement is measured by a micrometer depth gage of 50 mm range and 0.01 mm resolution.

Full reliance should not be placed on surface measurement alone. It should be recognized that all parts of a joint do not open at the same time, nor even the same amount. Thus, a lot of information on joint opening is gained from internally located joint meters (Encardio-rite model EDJ-31/34V). In some cases, where knowledge of shearing movement is desired, surface measurements can be made to advantage where joints are accessible in the galleries or at the surface.

Specifications are subject to change without notice.

ENCARDIO-RITE ELECTRONICS PVT. LTD.

A-7 Industrial Estate, Talkatora Road, Lucknow, UP 226011, India

Tel +91 (522) 2661044, 2661040 Fax +91 (522) 2661043 E-mail sales@encardio.com

Visit us at: www.encardio.com