



ENCARDIO RITE

ONE STOP MONITORING SOLUTIONS | HYDROLOGY | GEOTECHNICAL | STRUCTURAL | GEODETIC
Over 50 years of excellence through ingenuity

USERS' MANUAL

RESISTANCE STRAIN GAGE TYPE CENTRE HOLE LOAD CELL

MODEL ELC-30S



Doc. # WI 6002.39 R04 | Jan 2019

ENCARDIO-RITE ELECTRONICS PVT. LTD.

A-7, Industrial Estate, Talkatora Road Lucknow, UP - 226011, India | P: +91 522 2661039-42 | Email: geotech@encardio.com | www.encardio.com

International: UAE | Qatar | Bahrain | Bhutan | Greece | Denmark | USA

India: Lucknow | Delhi | Kolkata | Mumbai | Chennai | Bangalore | Hyderabad | J&K

Contents

1	INTRODUCTION	1
1.1	Application areas	1
1.2	Advantage of resistive strain gage type load cells	1
1.3	Handling of load cell	1
1.4	Conventions used in this manual	2
1.5	How to use this manual	2
2	STRAIN GAGE TYPE CENTRE HOLE LOAD CELL	3
2.1	General description	3
2.1.1	Bearing and load distribution plates	3
2.1.2	Cable connection	4
2.2	Sample Test Certificate	5
2.3	Tools & accessories required for installation	6
3	INSTALLATION PROCEDURE	7
3.1	Preparation of sensor before installation	7
3.2	Mounting load cell	7
3.3	Cable laying	9
3.3.1	General precautions in laying cable	9
3.4	Trouble shooting	9
3.4.1	Symptom: Load cell reading unstable	10
3.4.2	Symptom: Load cell fails to read	10

1 INTRODUCTION

Encardio-rite model ELC-30S centre hole load cell is precision engineered & specially designed for civil engineering applications. It comprises of a high strength martensitic stainless steel cylinder. Eight strain gages mounted at 45° to each other to minimize effect of uneven and eccentric loading are connected in a Wheatstone bridge circuit.

Load cells are available in standard capacities ranging from 200-2000 kN. Load cells having internal diameter different from our standard range are available on request.

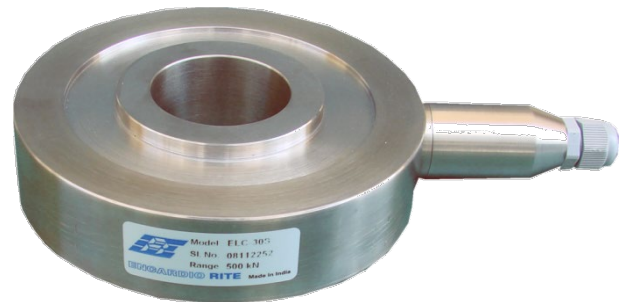

1.1 Application areas

It may be used to measure tensile force in a ground anchor, rock bolt, cable or tie back. It can also be applied to the measurement of compressive load between structural members, i.e. tunnel supports or at the junction between a beam and the top of a pile strut.

Collapse of roof or falling of side wall in underground cavities is a factor of prime importance to geologists, design engineers and construction companies. Slope failures and landslides have been recognized as one of the several forms of natural disaster and can happen anywhere in the world without any discrimination. Whether it is giving away of roof of a mine or buckling of side wall of an underground power house cavity or a landslide or a slope failure, the disaster may cause mammoth loss of life, property, wealth and time. A number of methods are available for taking preventive and corrective action. One method is anchoring. Use of pre-stressed grouted anchors provides an active support system.

1.2 Advantage of resistive strain gage type load cells

ELC-30S load cell is designed for use in environment normally associated with construction activity. Advantage of a conventional strain gage load cell over a vibrating wire load cell lies mainly in ease of taking the reading. Load can be directly read on a suitable indicator. In contrast, the vibrating wire load cell has three (or six) separate elements. These have to be separately read and the average taken to get the correct load. Data logging also in case of vibrating wire load cells requires three (or six) channels.

Model ELC-30S resistive strain gage type centre hole/anchor bolt load cell is hermetically sealed by electron beam welding with a vacuum of 1/1000 Torr inside it, making it immune to ingress of water and to most corrosive environments.

1.3 Handling of load cell

The load cell should be handled very carefully during transportation and installation. It should not be dropped under any circumstances. In case, it is dropped, the impact generated will almost certainly result in a shift of zero reading. Refer to Encardio-rite application note AN-1 (data sheet 1147-96) for an appreciation of the magnitude of damage caused to a load cell by impact load.

CAUTION: The load cell should not be dropped under any circumstances because this may lead to its permanent damage.

1.4 Conventions used in this manual

WARNING! Warning messages calls attention to a procedure or practice, that if not properly followed could possibly cause personal injury.

CAUTION: Caution messages calls attention to a procedure or practice, that if not properly followed may result in loss of data or damage to equipment.

NOTE: Note contains important information and is set off from regular text to draw the users' attention.

1.5 How to use this manual

This users' manual is intended to provide you with sufficient information for making optimum use of the strain gage type centre hole load cell in your application.

NOTE: The installation personnel must have a background of good installation practices and knowledge of the fundamentals of geotechnics. Novices may find it very difficult to carry on the installation work. The intricacies involved in installation are such that even if a single essential but apparently minor requirement is ignored or overlooked, the most reliable of instruments will be rendered useless.

A lot of effort has been made in preparing this instruction manual. However the best of instruction manuals cannot provide for each and every condition in the field, which may affect the performance of the sensor. Also, blindly following the instruction manual will not guarantee success. Sometimes, depending upon field conditions, the installation personnel will have to consciously depart from the written text and use their knowledge and common sense to find the solution to a particular problem.

To make this manual more useful we invite your valuable comments and suggestions regarding any additions or enhancements. We also request you to please let us know of any errors that you may find while going through the manual.

The manual is divided into a number of sections. Each section contains a specific type of information. The list given below tells you where to look for in this manual if you need some specific information.

For general description and dimensions: See § 2.1 'General description'.

For dimensions of load distribution & bearing plates: See § 2.1.1 'Bearing & load distribution plates'.

For wiring diagram: See § 2.1.2 'Cable connection'.

For essential tools and accessories: See § 2.3 'Tools and accessories required for installation'.

For installation of strain gage type centre hole load cells: See § 3 'Installation procedure'.

For trouble shooting: See § 3.4 'Trouble shooting'.

2 STRAIN GAGE TYPE CENTRE HOLE LOAD CELL

2.1 General description

The strain gages are mounted in a groove at the base of a stainless steel columnar element. A stainless steel diaphragm is electron beam welded to the element to cover the groove resulting in a vacuum of around 1/1000 Torr inside the sensor. All this helps in sensor becoming immune to atmospheric corrosion and effect of ingress of water. The sectional area of the columnar element and the depth of the groove in it is varied in different capacity load cells to give approximately the same mV/V output for a variation of zero to full load.

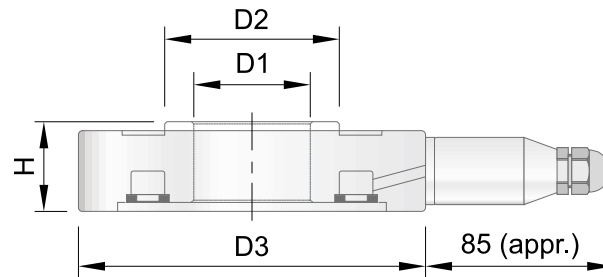

Item	Description	Qty
1	Load cell	1
2	Cable joint housing	1
3	Cable gland - PG 9	1

Capacity	Centre Hole Load Cell			
kN	D1 mm	D2 mm	D3 mm	H mm
200	40	60	155	40
500	52	78	155	40
1000	78	116	200	40
1000	105	138	225	40
1500	85	130	225	55
1500	130	165	260	55
2000	105	160	260	55
2000	155	192	260	55

2.1.1 Bearing and load distribution plates

Centre hole load cells are very susceptible to eccentric loading. The effect is reduced by providing a load distribution plate of proper dimensions at the top. In some applications, a load bearing plate may also be used at the bottom of the load cell. Standard plates stocked by Encardio-rite have the following dimensions:

Capacity	T mm	Bearing plate			Load distribution plate		
		OD mm	ID mm	Wt. kg	OD mm	ID mm	Wt. kg
200	23	155	116	2	75	40	1
500	35	155	116	2.5	98	52	1.5
1000	45	200	150	5	135	78	3.5
1000	45	225	172	6	155	105	4

Capacity		Bearing plate			Load distribution plate		
1500	55	225	165	8	150	85	5.5
1500	55	260	200	9.5	180	130	5.5
2000	65	260	195	12	180	105	9
2000	65	260	226	7	210	155	8.5

2.1.2 Cable connection

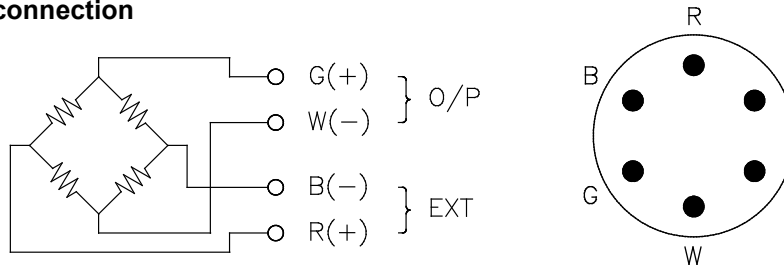

Leads from the Wheatstone bridge circuit are terminated on a six pin glass to metal seal (2 pins blank) which is integrally electron beam welded to the stainless steel body of the centre hole load cell. A cable joint housing and cable gland is provided for cable connection.

2.2 Sample Test Certificate

TEST CERTIFICATE

Date:
Temp.

Customer:

P.O. No.

Instrument:

Capacity

Mfg. Sr. No.

Model: ELC-30S strain gage type center hole load cell
1500 kN
0307518

Dimension details

	I.D.(mm)	O.D.(mm)	Height(mm)
Load cell	130	260	55
Load distribution plate	130	180	55
Bearing plate	200	260	55

General details

Input resistance	771	Ohm
Output resistance	701	Ohm
Insulation resistance	>1000	Mega Ohm

Test data

Excitation Voltage 10.000 V

Input Load kN	Output (mV/V)	
	Cycle 1	Cycle 2
0	0.000	0.000
300	0.402	0.402
600	0.793	0.794
900	1.198	1.199
1200	1.601	1.602
1500	2.025	2.024

Max. non linearity 0.89 % fs
Rated output 2.025 mV/V @ 1500 kN

Linear gauge factor

- 1) 74.074 kN/mV (To be used to convert the mV o/p of load cell in engineering units when observations are taken in mV with Voltmeter or other read out units with customer)
- 2) 1481.48 (To be used to read the o/p in engineering unit when Encardio-rite readout unit EDI-53L is used for observations. Refer to attached annexure-1)

Wiring configuration

Colour	Signal
Red	+ Excitaion
Black	- Excitation
Green	+ Output
White	- Output

Cable Length

10 meter

Checked by

Tested by

2.3 Tools & accessories required for installation

The following tools / accessories are required for proper cable jointing and installation of the load cell:

1. Soldering iron 25 watt, temperature controlled
2. Rosin 63/37 solder wire RF-3C, 30 swg.
3. Thread sealant (Loctite 577 or equivalent)
4. Cable jointing compound (MS 853 and hardener MSH 283 - Mahendra Engineering & Chemical Products Ltd. or equivalent. For alternatives, refer to note on page 3-3 of Encardio-rite user's manual "cable jointing of sensors" 6002.11)
5. Accessories for cable jointing compound i.e. rotary tin cutter, stainless steel rod 2 mm ϕ , 150 mm length for stirring, spatula & pouring funnel
6. Acetone (commercial)
7. Tooth brush
8. Cloth for cleaning (lint less)
9. Wire stripper and cable cutter
10. Pliers 160 mm
11. Spanner 18/19
12. Fixture for jointing up to five load cells
13. Digital multi-meter
14. Encardio-rite model EDI-53L digital indicator/logger

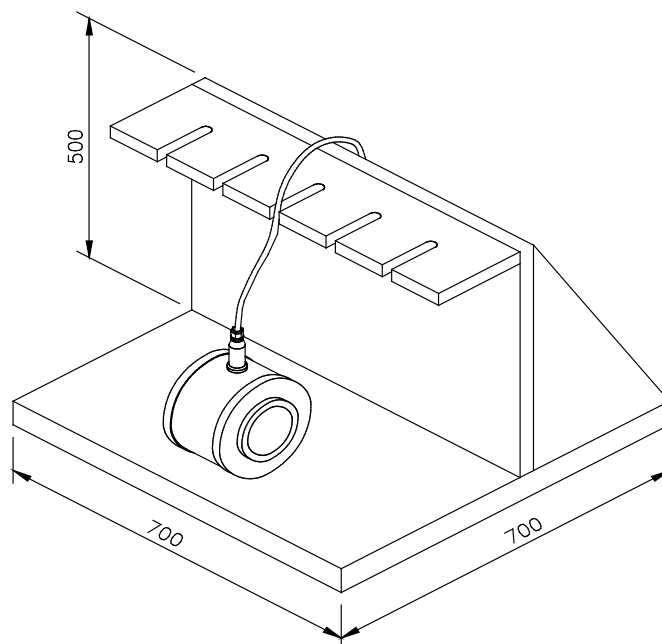

3 INSTALLATION PROCEDURE

3.1 Preparation of sensor before installation

3.1.1 Remove cable joint housing from cable end of sensor. This gives access to six pin terminals. Only four terminals are used. The active terminals are marked with red, black, white and green colour dots. Clean terminals with a tooth brush.

NOTE: Do not use any acetone for cleaning terminals as it may damage the glass to metal seal. Acetone should be used to clean other portions of the sensor.

3.1.2 Check working of the sensor as follows:

- Resistance measured by a digital multi-meter between red/black terminals should be $770 \text{ Ohm} \pm 5 \%$ and between green/white terminals should be $700 \text{ Ohm} \pm 1 \%$
- Resistance between any lead and outer casing should be $> 500 \text{ M Ohm}$.
- Using portable digital indicator measure zero balance of load cell. It should be between $\pm 0.2 \text{ mV/V}$.

NOTE: Check sensor for proper functioning before installation.

3.1.3 Check cable visually for any cuts, damaged sheath etc. Cut appropriate length of cable (add 1 m extra length for cable jointing). Always determine correct length of cable required. Cable to cable jointing should as far as possible be avoided.

CAUTION: Cable should always be removed from a spool by rotating the spool. This will reduce chances of nicking, bending or twisting of the cable.

3.1.4 Connect required length of cable to sensor as described in operating manual on cable jointing # WI-6002.11E.

3.1.5 Check working of the sensor again following the procedure described in § 3.1.2.

NOTE: Add cable resistance when checking resistance between leads after cable jointing. For EC-0107 cable (7 x 0.25 conductor) resistance is around 49 Ohm/km (multiply by 2 for both leads). In case any other cable is used, make necessary addition in resistance value.

3.2 Mounting load cell

3.2.1 Load cell assembly should always be mounted on a machined seating pad of thickness greater than flat bearing plate. Seating pad should be grouted perpendicular to axis of anchor and its top surface



Centre hole load cell installed on anchored sheet pile

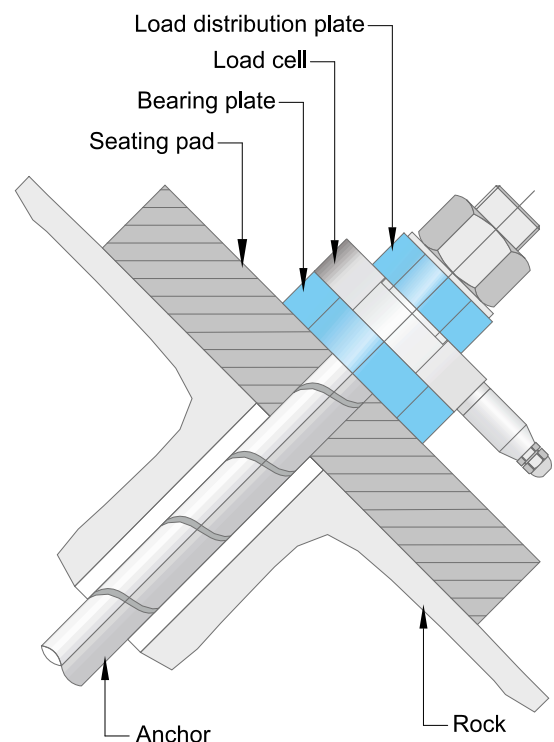

Typical Mounting of load cell

should preferably be ground. Centre hole load cell should be installed between flat bearing and load distribution plates. These plates should be parallel to each other and normal to axis of load cell. The anchor can be centralized by carefully positioning load cell over it. Alternatively, a suitable bush can be used in the annular space between load cell and anchor to centralize it taking care that bush does not interfere with the loading pattern of load cell. In case surface of the flat bearing and load distribution plates cannot be maintained parallel, spherical settings or wedges or compensation washers made of copper/high density plastic material should be used.

NOTE: Eccentric loading and uneven or warped bearing and load distribution plates have a profound effect on the load cell reading. Having thicker top and bottom plates reduces the effect. In case this problem is encountered, to start with as a rule of the thumb, use 23, 35, 45, 55, and 65 mm thick top and bottom plates for the 200, 500, 1000, 1500, and 2000 kN load cells respectively.

Careful mounting is required to reduce effect of eccentric loading. The load cell should be mounted between flat bearing top and bottom plates of proper thickness depending upon the load cell capacity. The bearing and load distribution plates are **ground flat** for improved performance. The load should be centralized with respect to load cell axis. In case the surfaces are not parallel, spherical settings or wedges should be employed. Compensation washers made of copper, high density plastic or any similar deformable material may also be used.

3.2.2 Pre-tension load cell as specified in design specifications. This can be done by connecting the Encardio-rite model EDI-53L portable digital indicator to load cell and monitoring load while tensioning anchor bolt or the cable anchor.

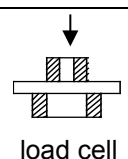
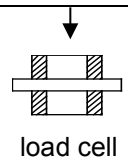
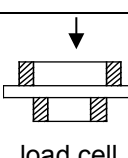
		Load cell response to applied load (500 kN)	
		23 mm thick plate	35 mm thick plate
Smaller bush		105 %	101%
Same size bush		100 %	100 %
Larger bush		96 %	99 %

NOTE: As already explained, an uneven bearing or load distribution plate can affect accuracy of reading, so can bending or distortion of plates. It is essential to use bearing/load distribution plates of correct thickness and finish. The hole in load distribution plate should match the internal diameter of centre hole load cell.

The effect of bearing/load distribution plates bending is illustrated by an experiment performed on an Encardio-rite 500 kN centre hole load cell, loaded on an universal testing machine to full capacity. For purpose of the experiment a flat plate was placed on the load cell and load applied through bushes of different diameters. The result is displayed below.

It will be noticed that if the bush is smaller or larger, the load cell reading is different from the actual reading. The effect is reduced in case the plate in-between is thicker. It is therefore advisable to use thick bearing and load distribution plates.

3.3 Cable laying

3.3.1 General precautions in laying cable

Careful and skilled cabling is required in the installation of a centre hole load cell. The load cell/cable joint and a large part of the cable may be exposed to blasting and construction work. They should be suitably protected. Part of the cable may be permanently embedded and no future access may be available for any maintenance and corrective action.

The procedure for laying of cables differs with individual installations. In general, however, all installations have the following common requirement:

- The cable must be protected from damage by angular and sharp particles of material in which cable is embedded.
- Cables may be spliced without affecting sensor reading; nevertheless splicing should be avoided wherever possible. If necessary, use special cable jointing kits available from the factory.

Precaution must be taken that the cables are properly tagged, onward from the point from which they come out of the load cell. With the best possible precautions, mistakes may still occur. Tags may get lost due to the cable getting accidentally cut. Encardio-rite uses the convention that looking from the junction box or the observation room towards the sensor, the cable from the most distant sensor is always at the left hand side. In that order, the cable from the closest sensor is at the extreme right.

NOTE: A simple code for remembering this is "LL-SR". Longer (cable) left, shorter (cable) right when viewing the sensors from the observation room.

CAUTION: All cables should be properly identified by tagging them every 5 m, onwards from the point from which they come out of the load cell. The tags should be of a non-corrosive material like stainless steel or plastics.

CAUTION: Follow the Encardio-rite convention that looking from the junction box or the observation room towards the sensor, the cable from the most distant sensor is always at the left hand side and the cable from the closest sensor is at the extreme right.

Similarly, as an Encardio-rite convention, the cable from the most distant sensor should be connected to the extreme left socket in the junction box. Succeeding cables from the sensors are connected progressively towards the right in the junction box.

Care should be taken that the wiring is neat and professional. If necessary all cables should be passed through MS/Copper/PVC solid or flexible tubing that should be clamped to the main frame at suitable intervals. The guiding principle should be to protect cable from any damage.

3.4 Trouble shooting

Once installed, remedial action is limited. Maintenance and trouble shooting is consequently confined to periodic checks of cable connection and functioning of the read-out unit. Refer to following list of problems and possible solutions should problems arise. For any additional help, consult factory.

3.4.1 Symptom: Load cell reading unstable

- Check insulation resistance. Resistance between any lead and outside casing should be $> 500 \text{ M Ohm}$. If not, cut a meter or so from end of cable and check again.
- Check if portable digital indicator works with another load cell? If not, the indicator may be malfunctioning. Consult manual of strain indicator for trouble shooting instructions.
- Use another portable digital indicator to take the reading.
- Check if there is a source of electrical noise nearby? General sources of electrical noise are motors, generators, transformers, arc welders and antennas. If so problem could be reduced by shielding from electrical noise.

3.4.2 Symptom: Load cell fails to read

- Cable may be cut or crushed? Check resistance between leads by a digital multi-meter. It should be $770 \text{ Ohm} \pm 5 \%$ between the red/black leads and $700 \text{ Ohm} \pm 1 \%$ between the green/white leads. If the cables are long, please add cable resistance when checking resistance (multiply by 2 for both leads). If resistance reads infinite or a very high value, a cut in the cable is suspected. If resistance reads very low ($< 100 \text{ Ohm}$), a short in cable is likely.
- Check if portable digital indicator works with another load cell? If not, the indicator may be malfunctioning. Consult manual of strain indicator for trouble shooting instructions.
- Use another portable digital strain indicator to take the reading.